

1. Derive ...

- (a) ... the thermal length L_T .
- (b) ... the interaction parameters r_s in 1D, 2D and 3D for a quadratic dispersion.
- (c) ... the cyclotron radius r_c .
- (d) ... the Zeeman splitting. Compare it to the Landau level spacing of the 2DEG.
- (e) ... the conductance quantization in a QPC. *Hint:* Use the explicit 1D expressions for the density of states and the velocity.

2. Classical and Quantum Hall Effect

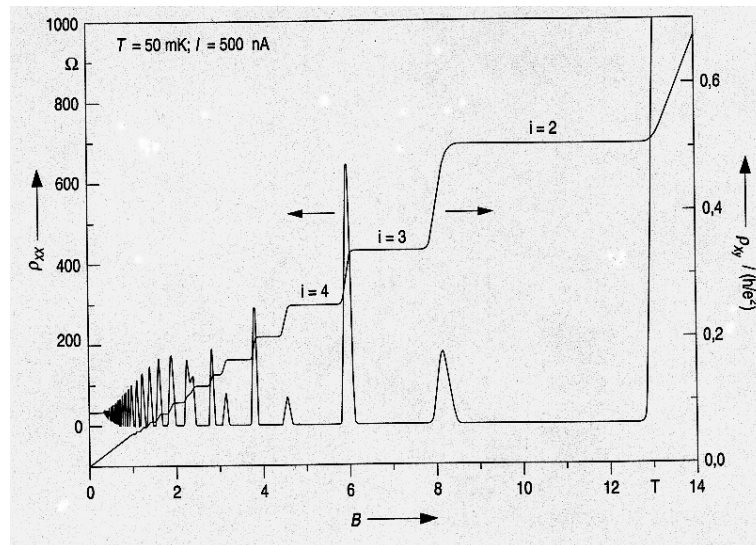

Use the low field data in the graph to estimate the electron density and mobility ...

- (a) Use the expression for the filling factor (script, equation 3.32) to derive an expression for the electron density.
- (b) Plot the peaks vs $1/B$ and estimate the period.
- (c) Calculate the electron density using the oscillation period extracted in (b).

3. Landauer-Büttiker Formalism with Quantum Hall Edge States

Consider a Hallbar as shown in the Figure in a strong magnetic field inducing integer quantum Hall states. Suppose there is an electron density gradient across the sample, leading to two regions with different filling factors ν_1 and ν_2 .

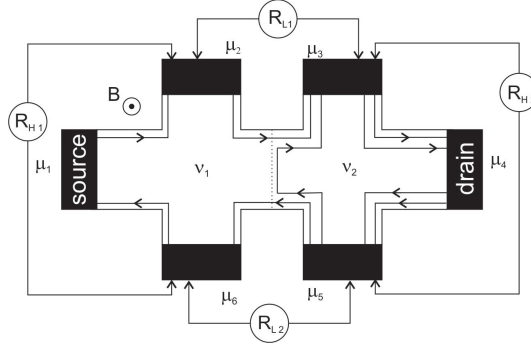

Assuming ballistic transport and perfect contacts (i.e. no back-scattering), derive the current through every contact via the incoming and outgoing edge channels using the Landauer-Büttiker formalism and Kirchhoff's current law. (*Hint:* Each channel has a conductance of $\frac{2e^2}{h}$ and carries the chemical potential of the contact it was emitted from.) Following this concept, one can write down a set of linear equations - one for each contact - using the potentials of the contacts. For example, contact 1 gives:

$$\frac{h}{2e}I = \nu_1\mu_1 - \nu_1\mu_6$$

with current I flowing through the source contact. The various resistances (see Figure) are defined by the difference of the potentials of the respective contacts and the current. For example: $R_{L1} = \frac{\mu_2 - \mu_3}{eI}$. To simplify the calculation, one can always choose one of the potentials to be zero (voltage reference). Let us assume the drain is grounded, $\mu_4 = 0$.

- Write down the equations for all contacts and solve for the chemical potential of each contact, assuming ν_1 and ν_2 are known. *Hint:* How much current is flowing through a voltage probe contact? Which current flows through the drain contact?
- Give the expressions for R_{L1} , R_{L2} , R_{H1} , R_{H2} and $R_{2t(1to4)}$.
- Qualitatively describe the result in terms of R_{xx} and R_{xy} .
- What happens if $\nu_1 = \nu_2$?
- What happens at the spot where the two edge states come together?